

# VirtualSCADA® VS-FIOA-0800-L User Manual



Revision 1.01.00

---

## Table of contents

<b>Warranty and support .....</b>	<b>3</b>
Product return .....	3
<b>1 About the VirtualSCADA VS-FIOA-800-L Field Analog Device.....</b>	<b>4</b>
1.1 General .....	4
1.2 Mounting .....	5
1.3 Connectors / Indicators .....	6
1.3.1 Power Supply .....	6
1.3.2 Analog Signal Input Connections .....	6
1.3.3 RS485 Port Connections.....	7
1.3.4 LED Indicators .....	7
<b>2 FIOA Device Configuration.....</b>	<b>8</b>
2.1 Communication Setup .....	8
2.2 Input Configuration.....	10
2.3 MODBUS Tags / Registers for analog inputs .....	10
<b>APPENDIX A: TECHNICAL SPECIFICATIONS .....</b>	<b>11</b>
<b>APPENDIX B: APPLICATIONS.....</b>	<b>12</b>

## Warranty and support

To obtain fast and simple support for your **VirtualSCADA VS-FIOA** products visit our website at [www.VirtualSCADA.com](http://www.VirtualSCADA.com)

### Product return

If you experience any problems with a **VirtualSCADA VS-FIOA** device and wish to have it repaired or exchanged, please follow these steps:

- Obtain a RMA Return Number, RMA, [www.VirtualSCADA.com](http://www.VirtualSCADA.com)
- To get this number you'll need to provide some information about the problem you have, contact information etc.
- Print the "RMA Number" and send it to us together with the product. Make sure the RMA is visible on the outside of the package, and that the delivery is pre-paid, otherwise the delivery won't be accepted by us. Also provide evidence of original purchase.
- If the faulty product is covered by the 12-month warranty, we will repair or exchange the device and return it within 30 days. If the product is not covered by Warranty we will advise an estimated repair cost.

# 1 About the VirtualSCADA Field Analog I/O Device

## 1.1 General

The **VirtualSCADA VS-FIOA** series products add analog capability to your PLC or SCADA System. The FIOA 0800 model has 8 analog (Voltage & current) inputs and a RS485 (2 wire) communication port. The RS485 communication port is used to connect to any MODBUS RTU master device (PLC / SCADA / Operator Interface).

### Features

- No setup required for analog inputs
- Pre-defined MODBUS RTU registers
- Baud-rate, parity, device address can be set with DIP-switches
- Din-rail mount
- Support for other VirtualSCADA products

The **VirtualSCADA VS-FIOA-800-L** device can be clicked onto a DIN rail. The drawing in section 1.2 shows dimensional details of FIOA device and DIN rail plate.

## 1.2 Mounting

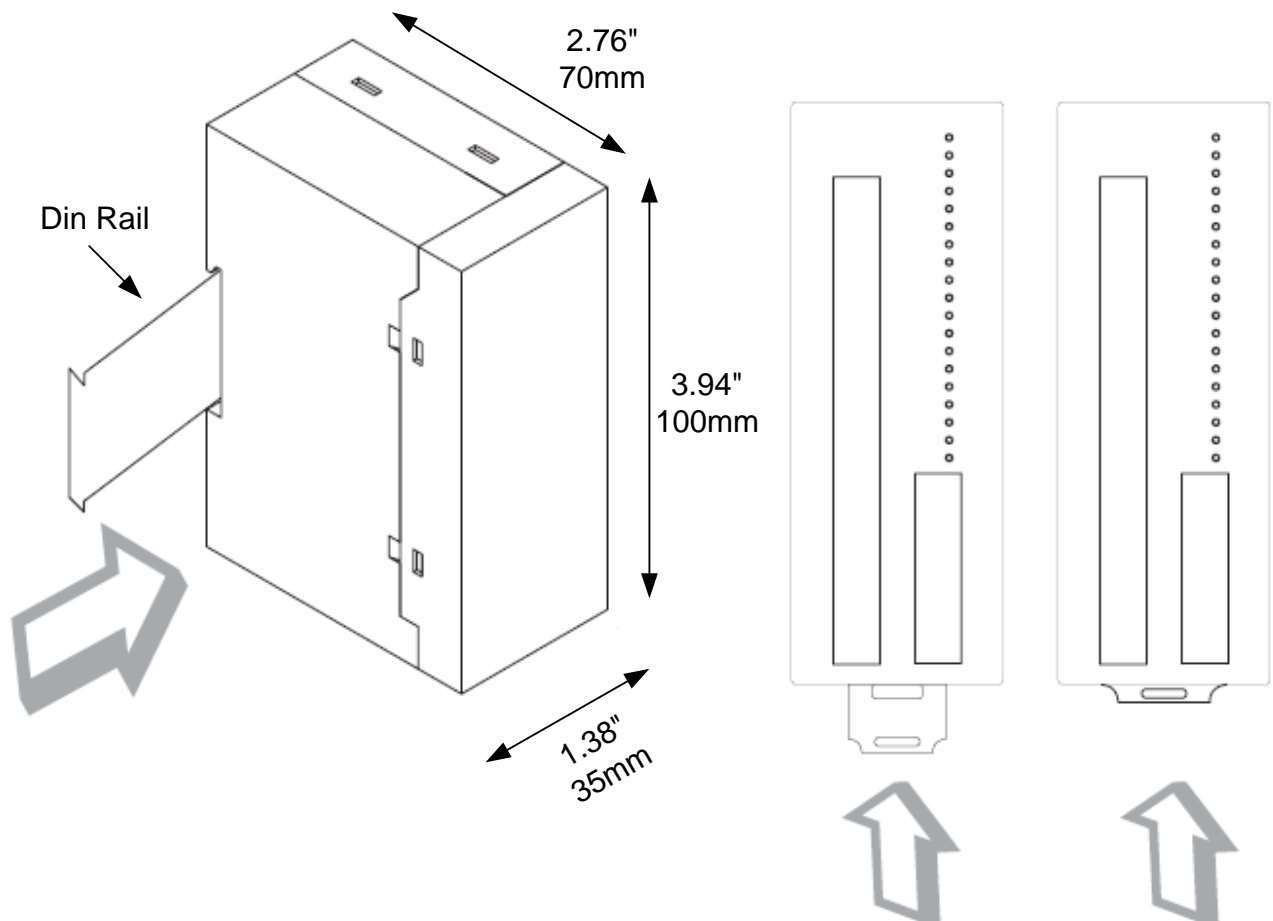

### Dimensions:

3.94" x 1.38" x 2.76" (H x W x D)

100mm x 35mm x 70mm (H x W x D)

Snap the **VirtualSCADA VS-FIOA device** onto the DIN-rail (as shown on the picture above).

### 1.3 Connectors / Indicators

#### 1.3.1 Power Supply

The VirtualSCADA VS-FIOA device is powered by a 24VDC supply (not included)

Power Supply: 24VDC / min. 90mA / 2W.

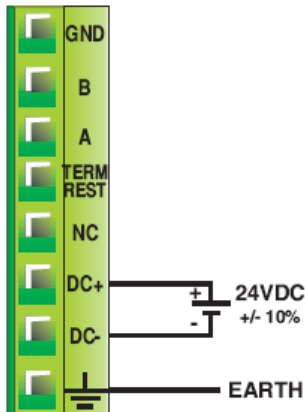

#### 1.3.2 Analog Signal Input Connections

Current Mode (4-20mA) Connections

Voltage Mode (0 – 10V) Connections

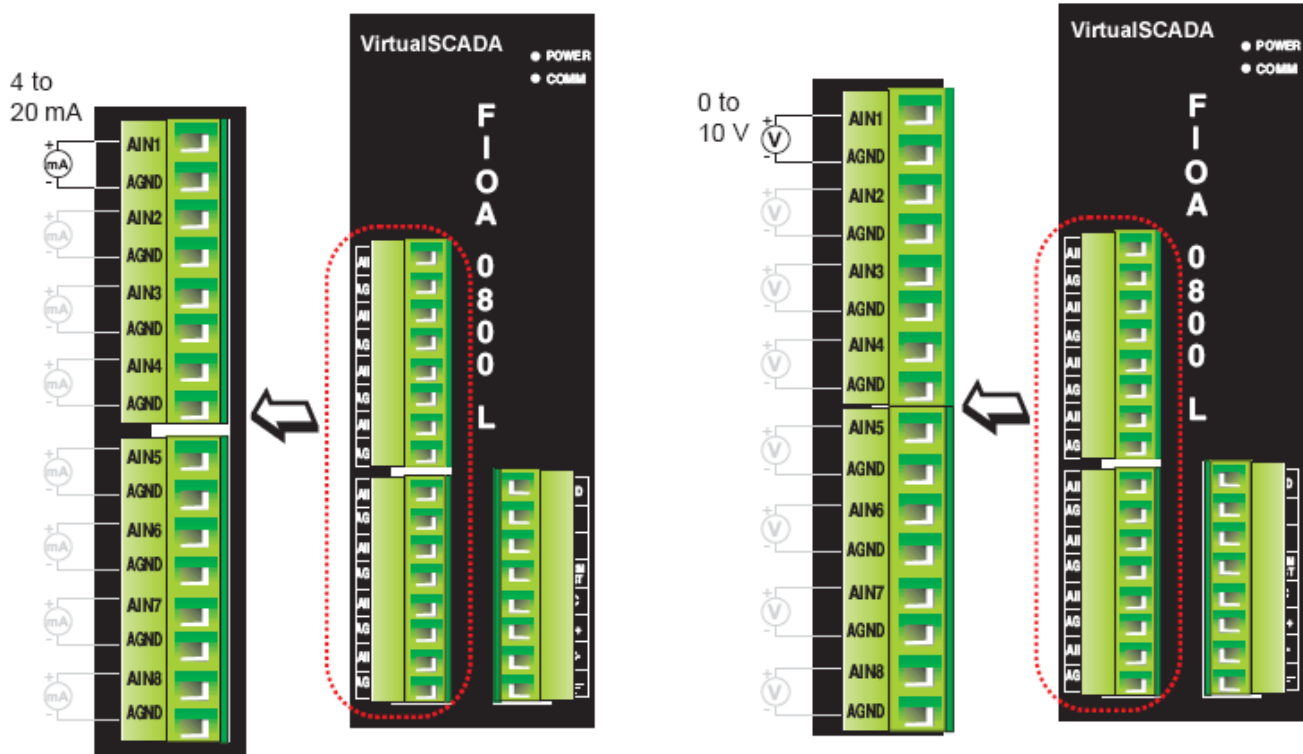

### 1.3.3 RS485 Port Connection

Connect A to + of the Modbus RTU RS485 Network and B to – of the Modbus RTU RS485 Network.

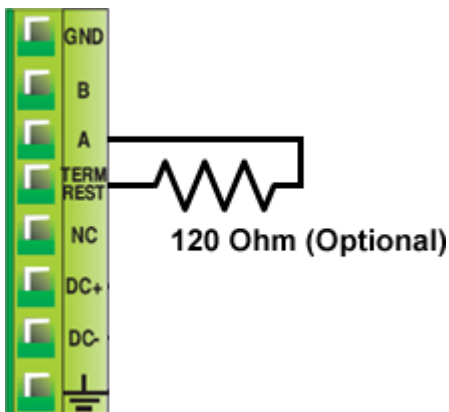
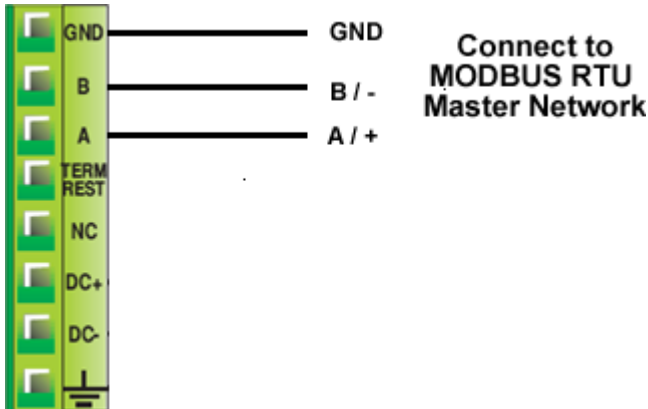

**Termination Resistor** (Optional / when required):

Install 120 Ohm / 0.25W resistor between terminal 'A' and terminal 'TERM-REST'

### 1.3.4 LED Indicators

#### LED description

Name	Color	Function
Power	OFF	No power
	On	Power supply turned on to device
Comm	OFF	No Communication
	Flashing	Communication active with master

## 2 FIOA Device Configuration

### 2.1 VirtualSCADA VS-FIOA communication setup

The device supports Modbus RTU driver for communication with the Master device. Dedicated Modbus registers are used monitoring the analog Voltage or Current inputs. The FIOA device scans all the inputs continuously and stores this information into each of the input registers. The communication parameters, device address and operation modes (Voltage / current) are set by means of a DIP switch.

A 10 position DIP Switch is used to set the Device Address, Baud Rate and Parity Setting

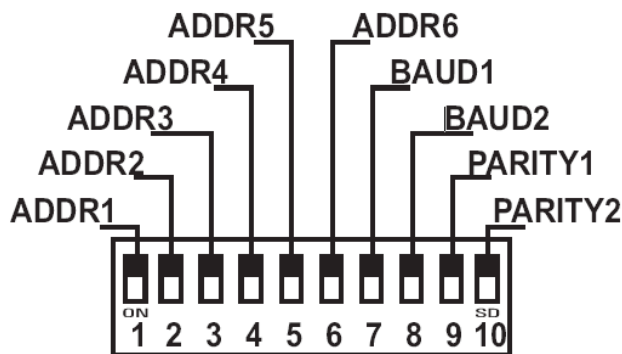

#### Device Address Setting

Device Address	Addr 6	Addr 5	Addr 4	Addr 3	Addr 2	Addr 1
	+32	+16	+8	+4	+2	+1
1	Off	Off	Off	Off	Off	Off
2	Off	Off	Off	Off	Off	On
3	Off	Off	Off	Off	On	Off
.						
64	On	On	On	On	Ob	On

Determine Device Address :

Each dip-switch (addr 1 to addr 6) can be set either Off (0) or On (1). To set the desired address simply set the switches so that the is '1' less than the desired address.

#### Example:

Device Address 27: Addr 5 is On (16), Addr 4 is On (8), Addr 2 is On (2) – 1 (offset) = 25

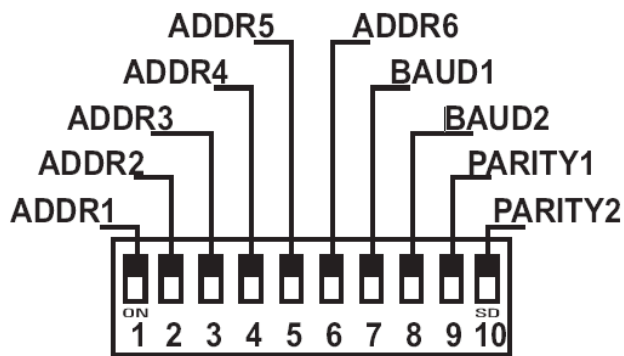

### Baud Rate Setting

Baud Rate	Baud 2	Baud 1
9600	Off	Off
19200	Off	On
57600	On	Off
115200	On	On

### Parity Setting

Baud Rate	Parity 2	Parity 1
None	Off	Off
Even	Off	On
Odd	On	Off

## 2.2 VirtualSCADA VS-FIOA input configuration

Each of the eight analog inputs can be configured for voltage or current input by means of the 8 position DIP switch on the FIOA Device.

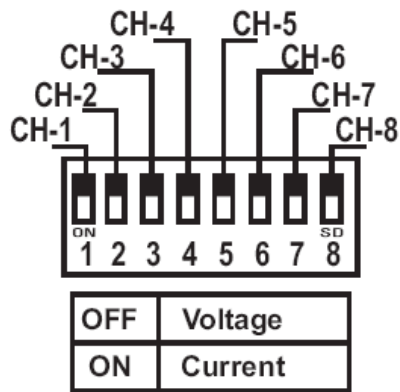

## 2.3 VirtualSCADA VS-FIOA MODBUS RTU Communication Registers

The following dedicated modbus registers are assigned to each of the analog inputs:

Analog Input	MODBUS RTU Tag / Register
<i>Input 1</i>	40001
<i>Input 2</i>	40002
<i>Input 3</i>	40003
<i>Input 4</i>	40004
<i>Input 5</i>	40005
<i>Input 6</i>	40006
<i>Input 7</i>	40007
<i>Input 8</i>	40008

**Data format: unsigned integer**

---

## APPENDIX A: Technical Specifications

<b>Power Supply:</b>	24 VDC +/- 10% (90mA / 2W)
<b>Analog Inputs:</b>	8 Voltage or current inputs (Input range: 0 to 10V and 4 to 20 mA)
<b>Resolution:</b>	12 Bits +/- 0.2% of scale +/- 1 bit
<b>Communication Port:</b>	2 Wire RS-485
<b>Protocol:</b>	MODBUS RTU
<b>I/O Terminals:</b>	Removable terminal blocks
<b>Operating Temperature:</b>	32F – 122F / 0°C to 50°C
<b>Storage Temperature:</b>	-4F – 176F / -20°C to 80°C
<b>Humidity:</b>	10% to 90% (non-condensing)
<b>Immunity to ESD:</b>	Per IEC610000-4-2
<b>Immunity to Fast Transients:</b>	Per IEC610000-4-4
<b>Immunity to Radiated Electromagnetic Field:</b>	Per IEC610000-4-3
<b>Immunity to Conducted Disturbances:</b>	IEC610000-4-6
<b>Surge:</b>	Per IEC610000-4-5
<b>Radiated Emission:</b>	IEC610000-4-4

APPENDIX B: Applications

Data Acquisition System: VirtualSCADA VS-U485 + VS-FIOA

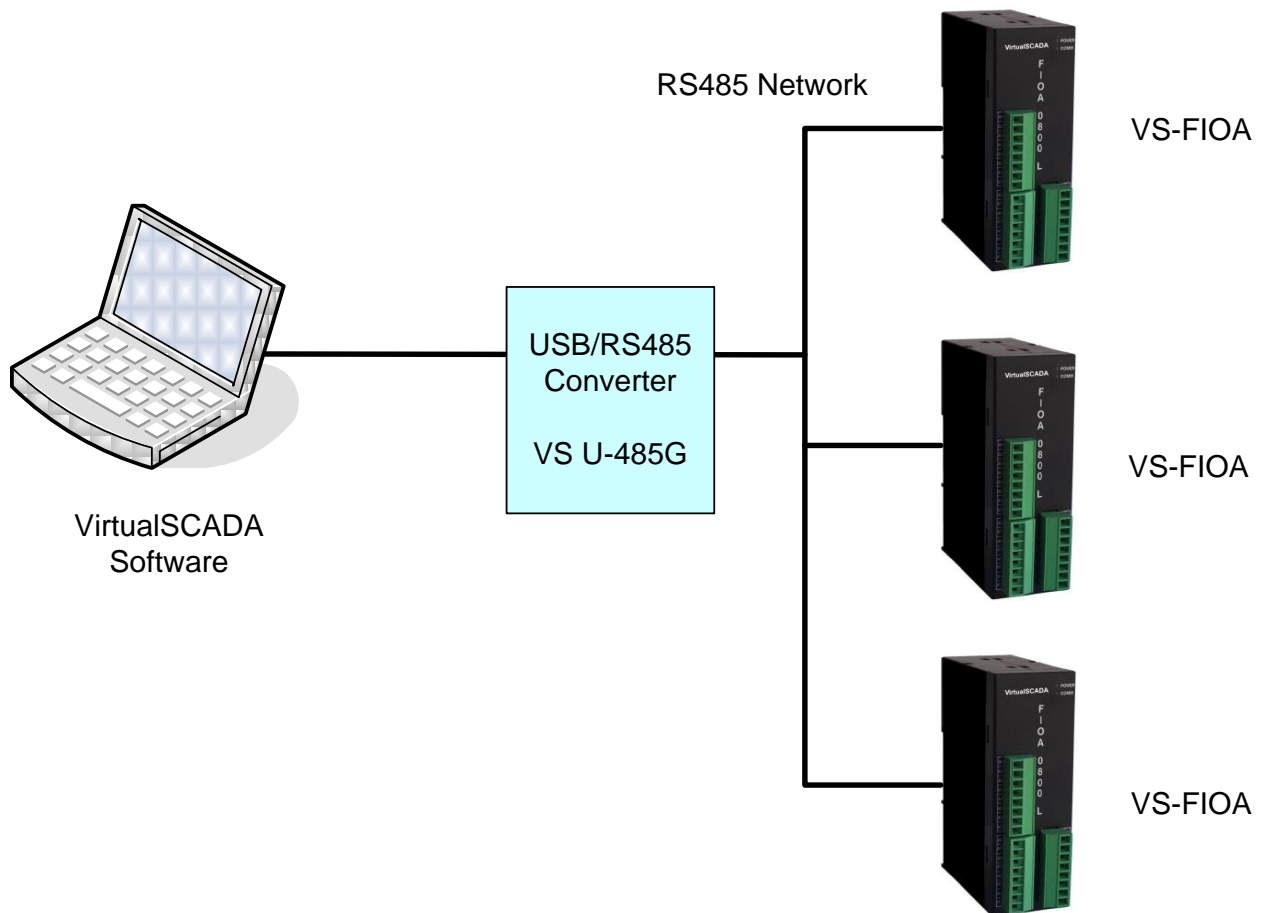

Web-browser SCADA Monitoring System: VirtualSCADA VS1 + VS-FIOA

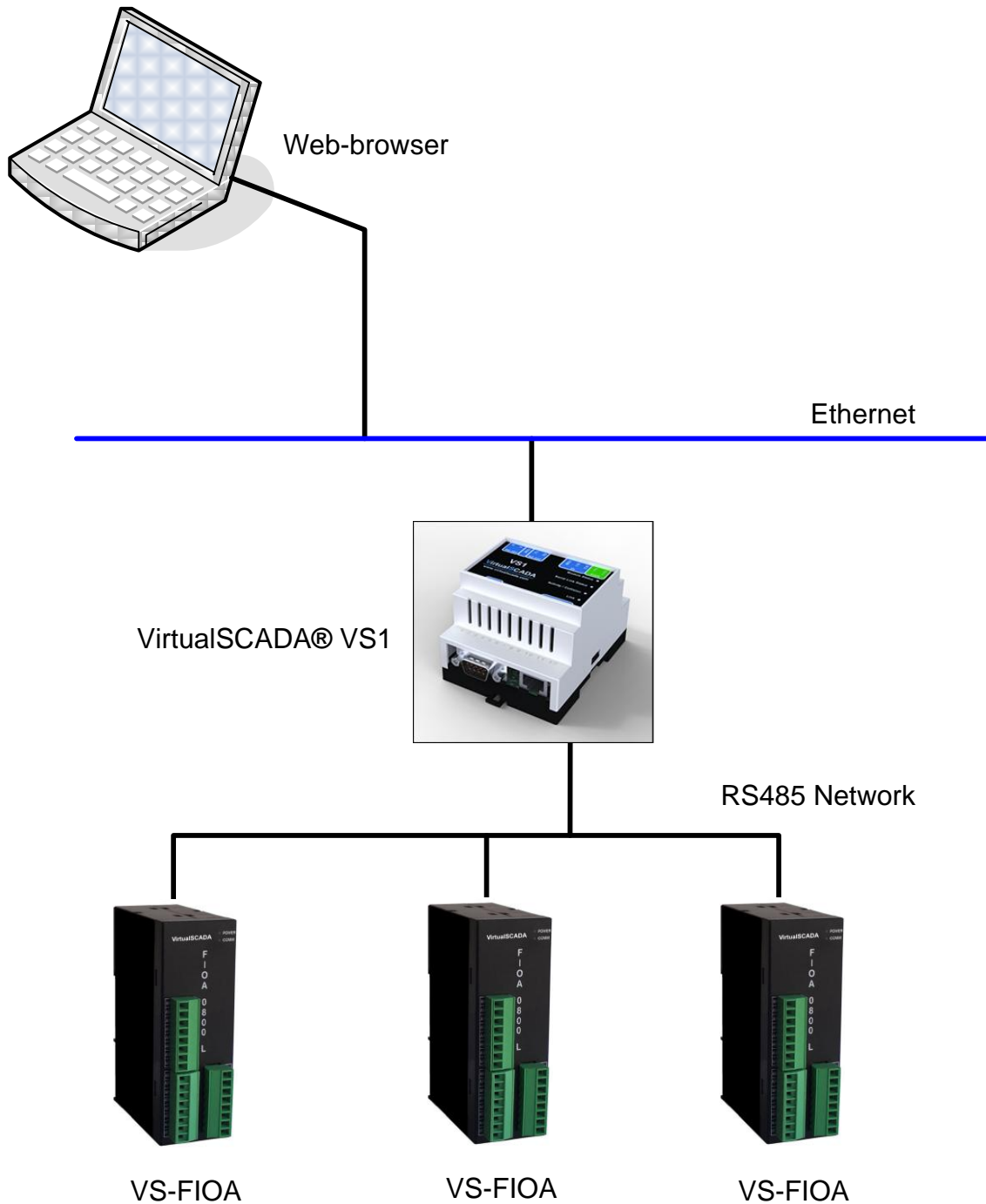

# VirtualSCADA®