

VirtualSCADA® VS-FIOD-0808 User Manual



Revision 1.00.00

Table of contents

Warranty and support	3
Product return	3
1 About the VirtualSCADA VS-FIOD-808 Field IO Device	4
1.1 General	4
1.2 Mounting	5
1.3 Connectors / Indicators	6
1.3.1 Power Supply	6
1.3.2 Digital Input Connections	6
1.3.3 Digital Output Connections.....	7
1.3.4 RS485 Port Connections.....	9
1.3.5 LED Indicators	9
2 FIOD Device Configuration.....	10
2.1 Communication Setup	10
2.2 MODBUS Tag / Register for digital inputs	12
2.3 MODBUS Tag / Register for digital outputs	12
2.4 MODBUS Tag / Register Timeout	13
APPENDIX A: TECHNICAL SPECIFICATIONS	11
APPENDIX B: APPLICATIONS.....	12

Warranty and support

To obtain fast and simple support for your **VirtualSCADA VS-FIOD** products visit our website at www.VirtualSCADA.com

Product return

If you experience any problems with a **VirtualSCADA VS-FIOD** device and wish to have it repaired or exchanged, please follow these steps:

- Obtain a RMA Return Number, RMA, www.VirtualSCADA.com
- To get this number you'll need to provide some information about the problem you have, contact information etc.
- Print the "RMA Number" and send it to us together with the product. Make sure the RMA is visible on the outside of the package, and that the delivery is pre-paid, otherwise the delivery won't be accepted by us. Also provide evidence of original purchase.
- If the faulty product is covered by the 12-month warranty, we will repair or exchange the device and return it within 30 days. If the product is not covered by Warranty we will advise an estimated repair cost.

1 About the VirtualSCADA Field I/O Device

1.1 General

The **VirtualSCADA VS-FIOD** series products add digital I/O capability to your PLC or SCADA System. The FIOD 0808 model has 8 digital inputs and 8 digital outputs (relay or transistor) and a RS485 (2 wire) communication port. The RS485 communication port is used to connect to any MODBUS RTU master device (PLC / SCADA / Operator Interface).

Features

- No setup required for digital I/O
- Pre-defined MODBUS RTU registers
- Baud-rate, parity, device address can be set with DIP-switches
- Din-rail mount
- Support for other VirtualSCADA products

The **VirtualSCADA VS-FIOD-808** device can be clicked onto a DIN rail. The drawing in section 1.2 shows dimensional details of FIOD device and DIN rail plate.

1.2 Mounting

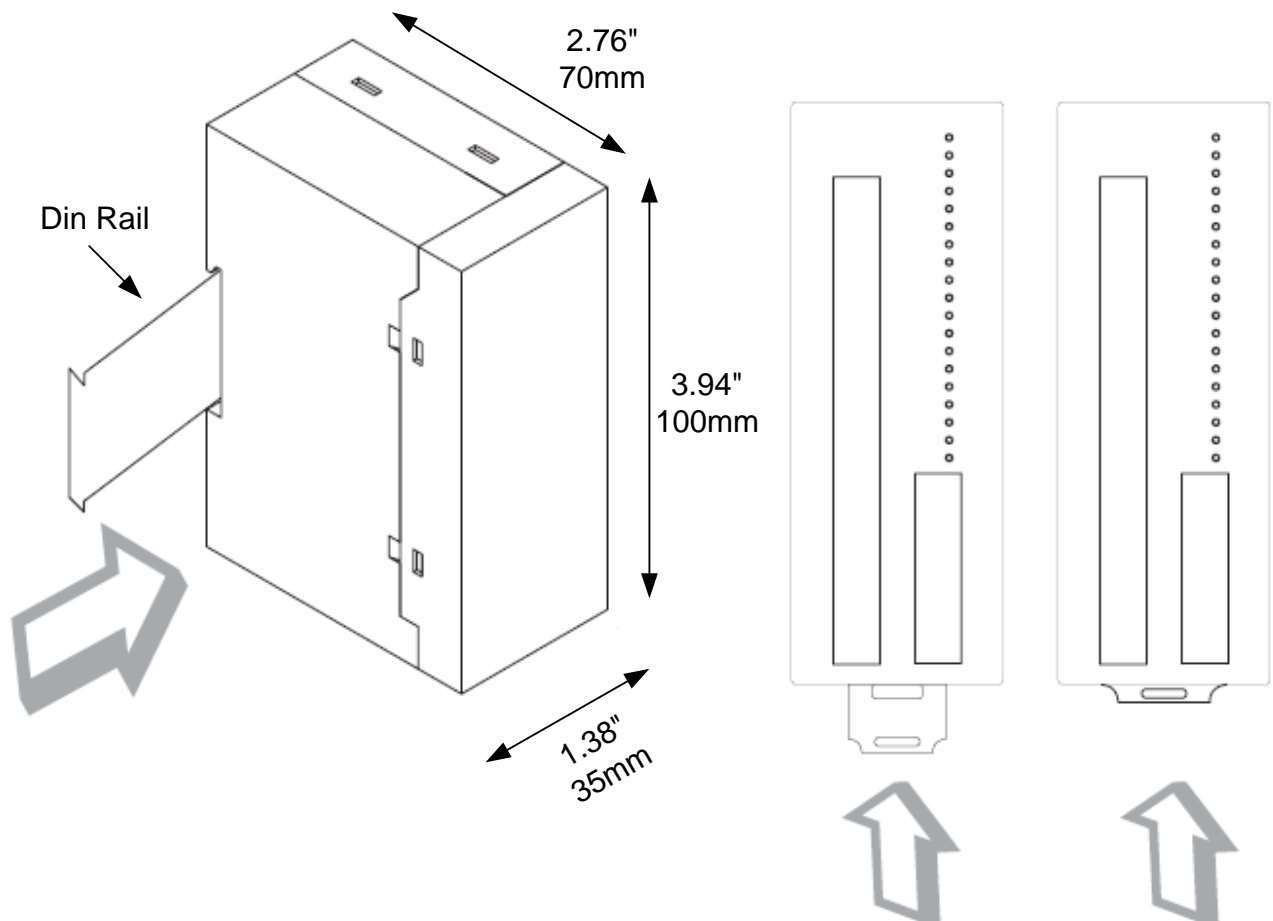

Dimensions:

3.94" x 1.38" x 2.76" (H x W x D)

100mm x 35mm x 70mm (H x W x D)

Snap the **VirtualSCADA VS-FIOD device** onto the DIN-rail (as shown on the picture above).

1.3 Connectors / Indicators

1.3.1 Power Supply

The VirtualSCADA VS-FIOD device is powered by a 24VDC supply (not included)

Power Supply: 24VDC / min. 90mA / 2W.

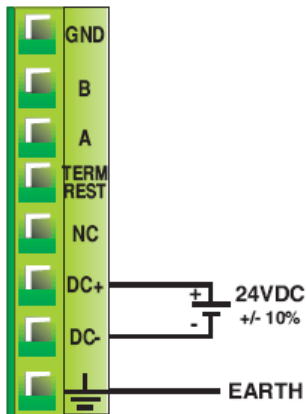

1.3.2 Digital Input Connections

The diagram below shows a typical test setup for the digital inputs.

Note: Make sure the input voltage does not exceed 24VDC.

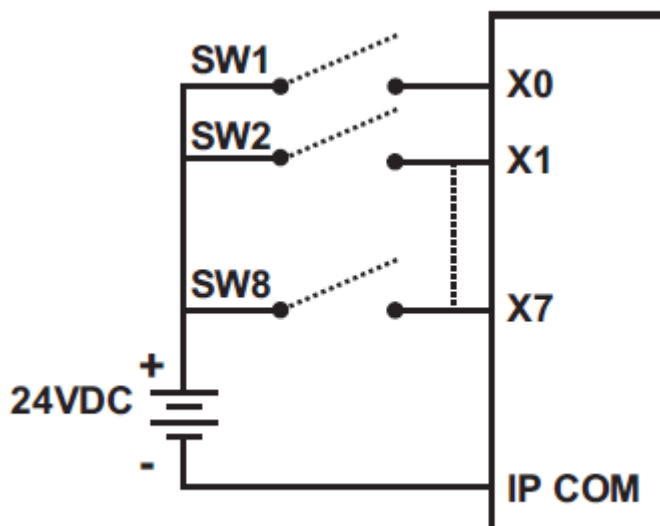

Digital Inputs: 0 to 5VDC = Low Level, 12 to 28VDC = High Level, Rated Input Current: 4mA,
Input Impedance: 5.6K Ohm

1.3.3 Digital Output Connection

Relay Outputs: Model VS-FIOD-0808-R-B

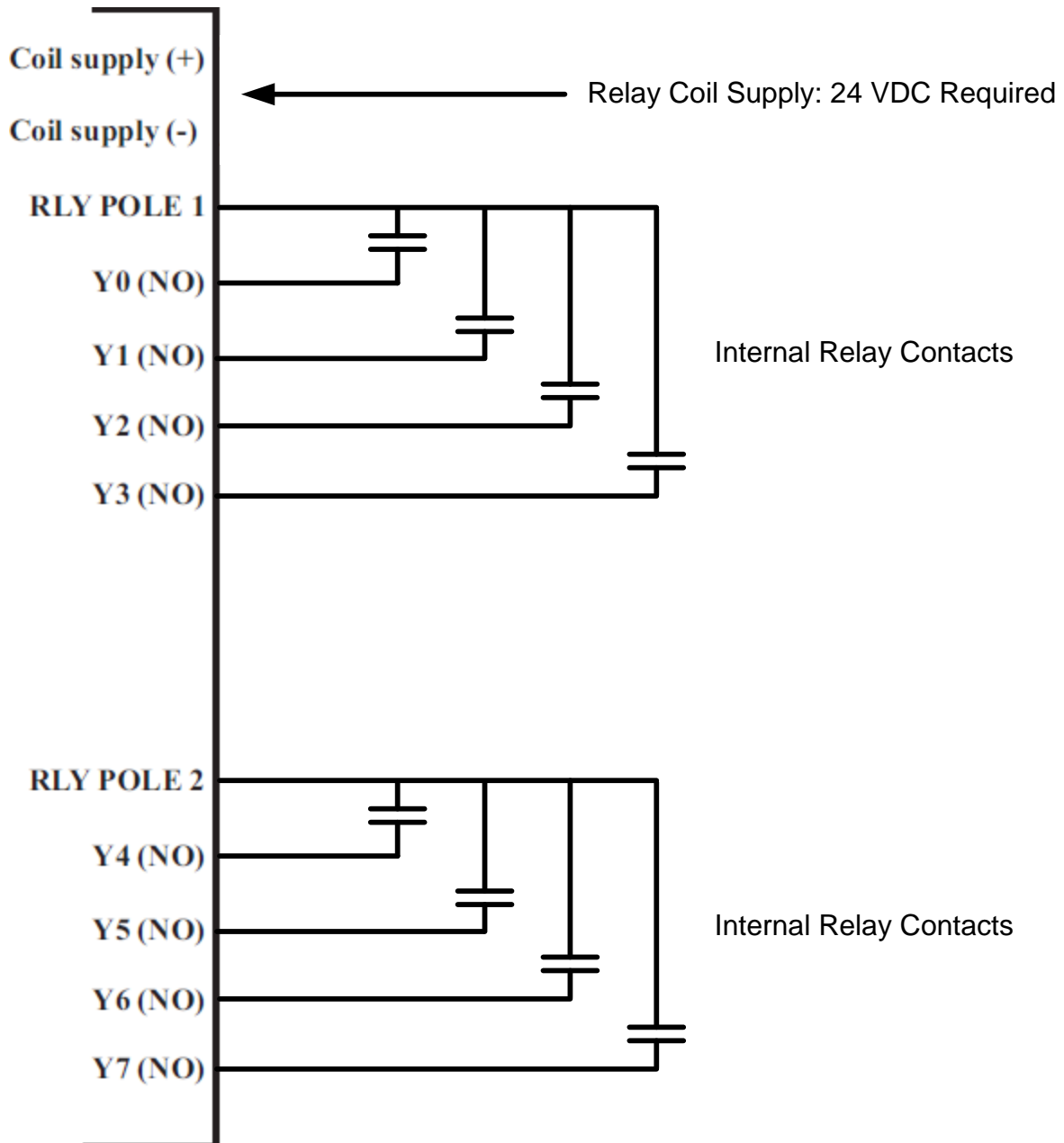

Relay Rating: Relay Outputs: 230VAC/30VDC, 2 Amps Max / Coil Voltage 24VDC

Transistor Outputs: Model VS-FIOD-0808-C-B / VS-FIOD-0808-P-B

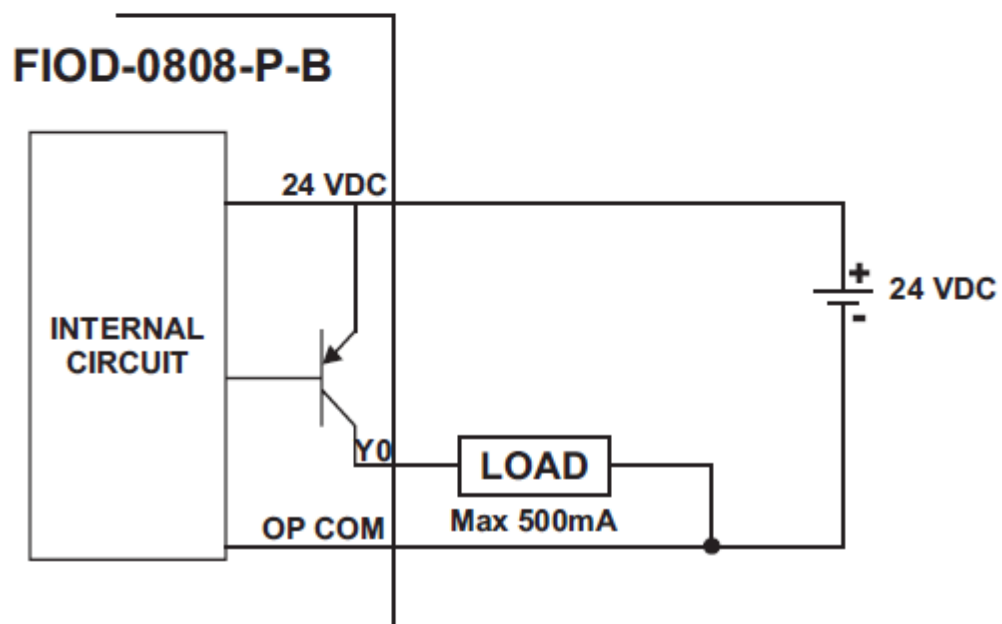
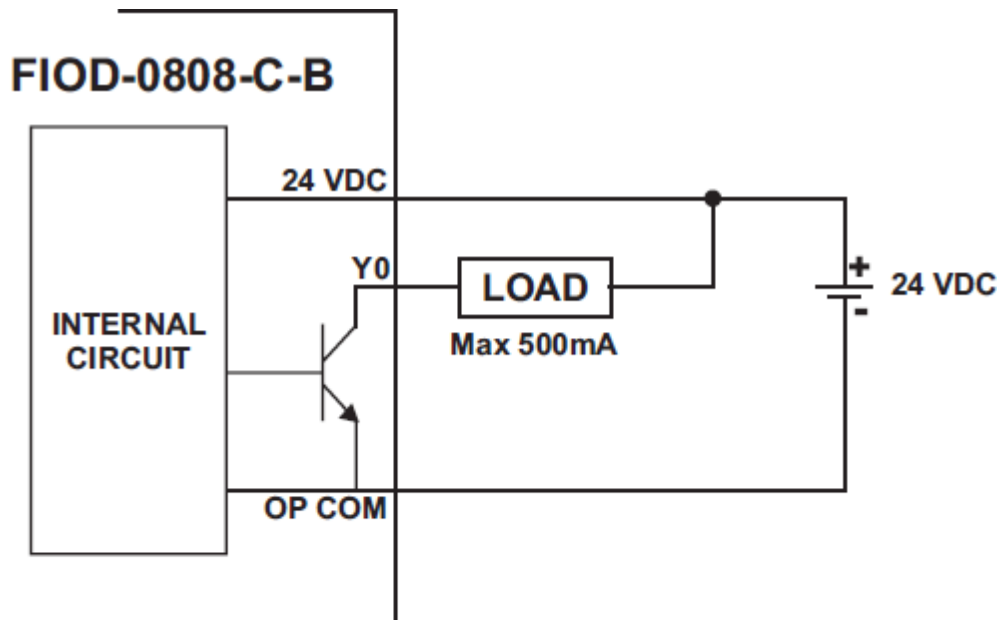

Transistor Rating: Transistor Outputs PNP/NPN 500mA Max, Supply Voltage 24VDC

1.3.4 RS485 Port Connection

Connect A to + of the Modbus RTU RS485 Network and B to – of the Modbus RTU RS485 Network.

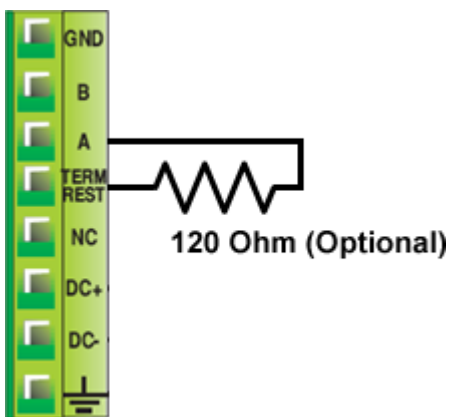
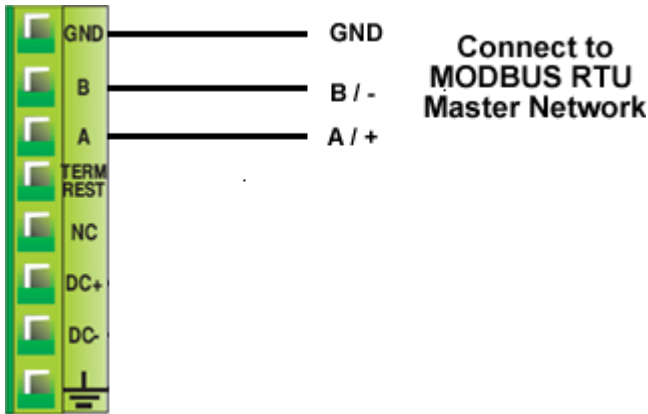

Termination Resistor (Optional / when required):

Install 120 Ohm / 0.25W resistor between terminal 'A' and terminal 'TERM-REST'

1.3.5 LED Indicators

LED description

Name	Color	Function
Power	OFF	No power
	On	Power supply turned on to device
Comm	OFF	No Communication
	Flashing	Communication active with master
Err	On/Flashing	Communication Error Detected

2 FIOD Device Configuration

2.1 VirtualSCADA VS-FIOD communication setup

The device supports Modbus RTU driver for communication with the Master device. Dedicated Modbus registers are used to monitor the digital inputs or control the digital outputs. The communication parameters, device address are set by means of a DIP switch.

A 10 position DIP Switch is used to set the Device Address, Baud Rate and Parity Setting

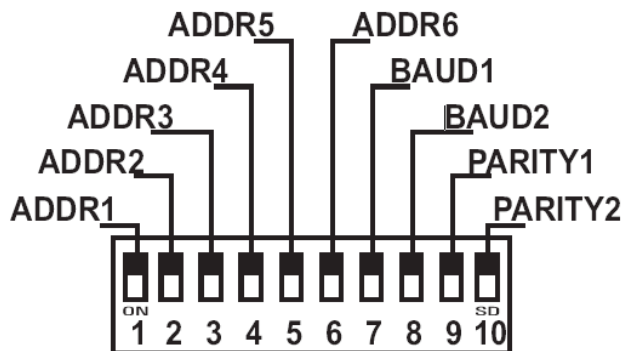

Device Address Setting

Device Address	Addr 6	Addr 5	Addr 4	Addr 3	Addr 2	Addr 1
	+32	+16	+8	+4	+2	+1
1	Off	Off	Off	Off	Off	Off
2	Off	Off	Off	Off	Off	On
3	Off	Off	Off	Off	On	Off
.						
64	On	On	On	On	Ob	On

Determine Device Address :

Each dip-switch (addr 1 to addr 6) can be set either Off (0) or On (1). To set the desired address simply set the switches so that the is '1' less than the desired address.

Example:

Device Address 27: Addr 5 is On (16), Addr 4 is On (8), Addr 2 is On (2) – 1 (offset) = 25

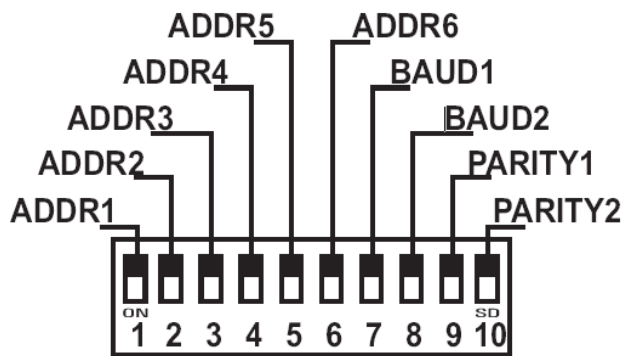

Baud Rate Setting

Baud Rate	Baud 2	Baud 1
9600	Off	Off
19200	Off	On
57600	On	Off
115200	On	On

Parity Setting

Baud Rate	Parity 2	Parity 1
None	Off	Off
Even	Off	On
Odd	On	Off

2.2 MODBUS Tag / Register for digital inputs

The following dedicated modbus registers are assigned to each of the digital inputs:

Digital Input	MODBUS RTU Tag	
	Input Register	Input Coil
<i>Input 1</i>	<i>40001_0 (Bit 0)</i>	<i>0001</i>
<i>Input 2</i>	<i>40001_1 (Bit 1)</i>	<i>0002</i>
<i>Input 3</i>	<i>40001_2 (Bit 2)</i>	<i>0003</i>
<i>Input 4</i>	<i>40001_3 (Bit 3)</i>	<i>0004</i>
<i>Input 5</i>	<i>40001_4 (Bit 4)</i>	<i>0005</i>
<i>Input 6</i>	<i>40001_5 (Bit 5)</i>	<i>0006</i>
<i>Input 7</i>	<i>40001_6 (Bit 6)</i>	<i>0007</i>
<i>Input 8</i>	<i>40001_7 (Bit 7)</i>	<i>0008</i>

Data format: unsigned integer

2.3 MODBUS Tag / Register for Digital Outputs

The following dedicated modbus registers are assigned to each of the digital outputs:

Digital Input	MODBUS RTU Tag	
	Output Register	Output Coil
<i>O/P1 (Y0)</i>	<i>40065_0 (Bit 0)</i>	<i>1025</i>
<i>O/P2 (Y1)</i>	<i>40065_1 (Bit 1)</i>	<i>1026</i>
<i>O/P3 (Y2)</i>	<i>40065_2 (Bit 2)</i>	<i>1027</i>
<i>O/P4 (Y3)</i>	<i>40065_3 (Bit 3)</i>	<i>1028</i>
<i>O/P5 (Y4)</i>	<i>40065_4 (Bit 4)</i>	<i>1029</i>
<i>O/P6 (Y5)</i>	<i>40065_5 (Bit 5)</i>	<i>1030</i>
<i>O/P7 (Y6)</i>	<i>40065_6 (Bit 6)</i>	<i>1031</i>
<i>O/P8 (Y7)</i>	<i>40065_7 (Bit 7)</i>	<i>1032</i>

Data format: unsigned integer

2.4 MODBUS Tag / Register Timeout

Modbus Tag	Tag Name	Type	Default	Valid Range	Description
40070	Communication timeout for unit communication frame	Retentive	100	1 – 65535 (x 100ms)	Specifies communication timeout time. If unit does not receive a valid frame within the time specified it will declare a timeout.
40071	Communication timeout for optimum communication	Retentive	100	1 – 65535 (x 100ms)	Specifies the communication timeout. If communication line is completely ideal (No frame from line master for other slaves also) within the specified timeout period, the unit declares a communication break.
40072_0 or Coil 01137	Selection bit	Retentive	0	0 or 1	If 1, timeout value from 40070 is selected If 0, timeout value from 40071 is selected

Note: The default timeout is 10sec.

In case of communication break with the host all the outputs are switched OFF after the timeout period is expired.

Data format: unsigned integer

APPENDIX A: Technical Specifications

Power Supply:	24 VDC +/- 10% (90mA / 2W)
Digital Inputs:	0 to 5VDC = Low Level 12 to 28VDC = High Level Rated Input Current: 4mA Input Impedance: 5.6K Ohm
Relay Outputs:	Relay Outputs: 230VAC/30VDC, 2 Amps Max Coil Voltage 24VDC
Transistor Outputs:	Transistor Outputs PNP/NPN 500mA Max, Supply Voltage 24VDC
Communication Port:	2 Wire RS-485
Protocol:	MODBUS RTU
I/O Terminals:	Removable terminal blocks
Operating Temperature:	32F – 140F / 0°C to 60°C
Storage Temperature:	-4F – 176F / -20°C to 80°C
Humidity:	10% to 90% (non-condensing)
Immunity to ESD:	Per IEC61000-4-2
Immunity to Fast Transients:	Per IEC61000-4-4
Immunity to Radiated Electromagnetic Field:	Per IEC61000-4-3
Immunity to Conducted Disturbances:	IEC61000-4-6
Surge:	Per IEC61000-4-5
Radiated Emission:	IEC61000-4-4

APPENDIX B: Applications

Data Acquisition System: VirtualSCADA VS1/V2 + VS-FIOD

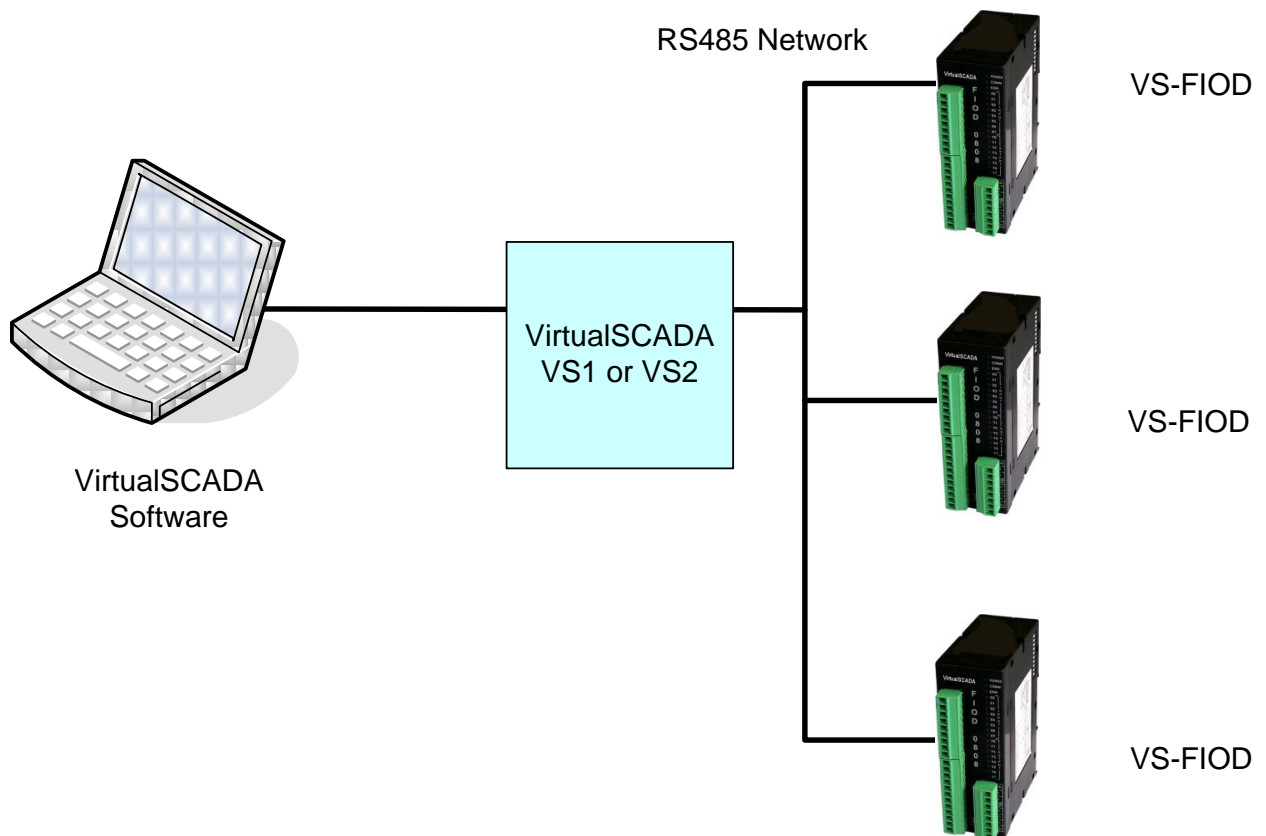

Web-browser SCADA Monitoring System: VirtualSCADA VS1 + VS-FIOD

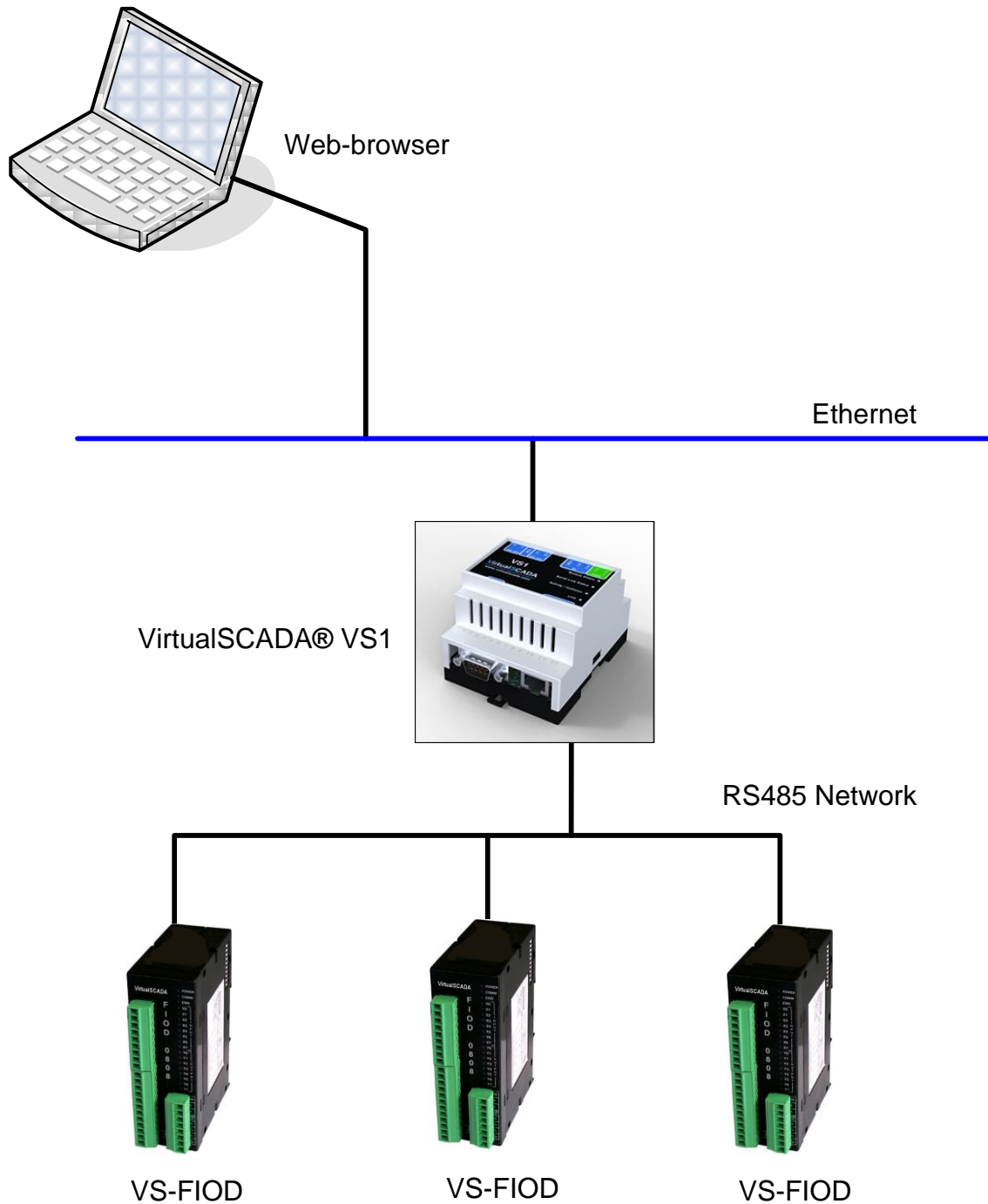

VirtualSCADA®