

Anybus Wireless Bridge Serial - Bluetooth Product Guide

Document Revision

Document number: XXX

Release: November 6, 2014

Document version: [1](#)

Table of Content

- [1 Table of Content](#)
- [2 Introduction](#)
 - [2.1 Related Documents](#)
 - [2.2 What is Bluetooth Wireless Technology?](#)
 - [2.3 How can I use my Serial Port Adapter?](#)
 - [2.4 Getting Started](#)
- [3 Installation](#)
 - [3.1 Anybus Wireless Bridge Serial - Bluetooth](#)
 - [3.1.1 Mounting](#)
 - [3.1.2 Power Supply](#)
 - [3.1.3 RS232](#)
 - [3.1.4 RS422](#)
 - [3.1.5 RS485](#)
 - [3.1.6 Button and LED](#)
- [4 Regulatory Information](#)
 - [4.1 FCC Statement](#)
 - [4.1.1 RF-Exposure Statement](#)
 - [4.1.2 Caution](#)
 - [4.2 Declaration of Conformity](#)
- [5 Bluetooth Qualification](#)
- [6 Additional Information](#)
 - [6.1 Guidelines for Efficient and Safe Use](#)
 - [6.1.1 Product Care](#)
 - [6.1.2 Radio Frequency Exposure](#)
 - [6.1.3 Electronic Equipment](#)
 - [6.1.4 Potentially Explosive Atmospheres](#)
 - [6.1.5 Power Supply](#)
 - [6.2 Troubleshooting](#)
 - [6.3 Technical Specifications](#)
 - [6.3.1 Environmental](#)
 - [6.3.2 Radio Output Power](#)
 - [6.3.3 Power Supply](#)
 - [6.3.4 Serial Interface](#)
 - [6.3.5 Housing](#)
 - [6.3.6 Dimensions](#)

Introduction

Congratulations on your purchase of an Anybus Wireless Bridge Serial – Bluetooth. This gateway can be used as a component in many types of systems allowing them to communicate wirelessly with other Bluetooth products such as PC-cards, laptops, handheld computers, mobile phones and other gateways or serial port adapters. The gateway is a suitable component in new products as well as in existing products. This guide especially focuses on how to mount the gateway and how to use the connectors.

Brief overview of the features of the Anybus Wireless Bridge Serial – Bluetooth:

Metal housing (IP65), long range (12 dBm), RS232/RS422/RS485 (DSUB) serial interface, stub antenna, accepts 8-30 VDC power supply. AT Mode and Extended Data Mode command interface.



Please read the chapter "Guidelines for Efficient and Safe use" before using the gateway.

Related Documents

- **Anybus Wireless Bridge Serial - Bluetooth Getting Started**
Describes the basic concept and functionality of the Wireless Bridge using Classic Bluetooth connections.
- **Anybus Wireless Bridge Serial - Bluetooth AT Commands**
Describes all AT commands, default values for AT commands, and possible constraints for different Wireless Bridge models.

What is Bluetooth Wireless Technology?

Bluetooth allows compatible portable and stationary communications devices to communicate without using cables. The technology is based on a radio link that offers fast and reliable transmission of voice and data information. It doesn't require a line-of-sight connection in order to establish and maintain communication. The Bluetooth wireless technology uses a globally available frequency range intended to ensure communication compatibility worldwide. Bluetooth is available in mobile phones, laptops, handheld computers, industrial devices, cars, and more.

How can I use my Serial – Bluetooth gateway?

Your gateway communicates with its host system using RS232, RS422, or RS485. Once connected to its host system and configured, the gateway can communicate, using Classic Bluetooth and/or Bluetooth low energy, with a wide range of other Bluetooth enabled devices such as other gateways, mobile phones, handheld computers and laptops.



Figure 1. The gateway connected to the controller communicates wirelessly with a Bluetooth enabled Laptop.

The gateway can initiate as well as accept connections to and from other Bluetooth devices. When initiating a connection to another device, the gateway acts as a client. When accepting a connection from another device, the gateway acts as a server. In most cases the gateway communicates with one Bluetooth device at a time, but it is possible to simultaneously communicate with several Bluetooth devices.

Getting Started

Before using your gateway you must:

- Install the gateway. For more information, see Installation section.
- Configure the gateway. For more information, please read the Getting Started section. It is also possible to use the Toolbox for easy test and configuration.

Installation

Before using the gateway it must be connected to its host system and it must be connected to a power supply. This chapter describes how to install the gateway.

Anybus Wireless Bridge Serial - Bluetooth

Mounting

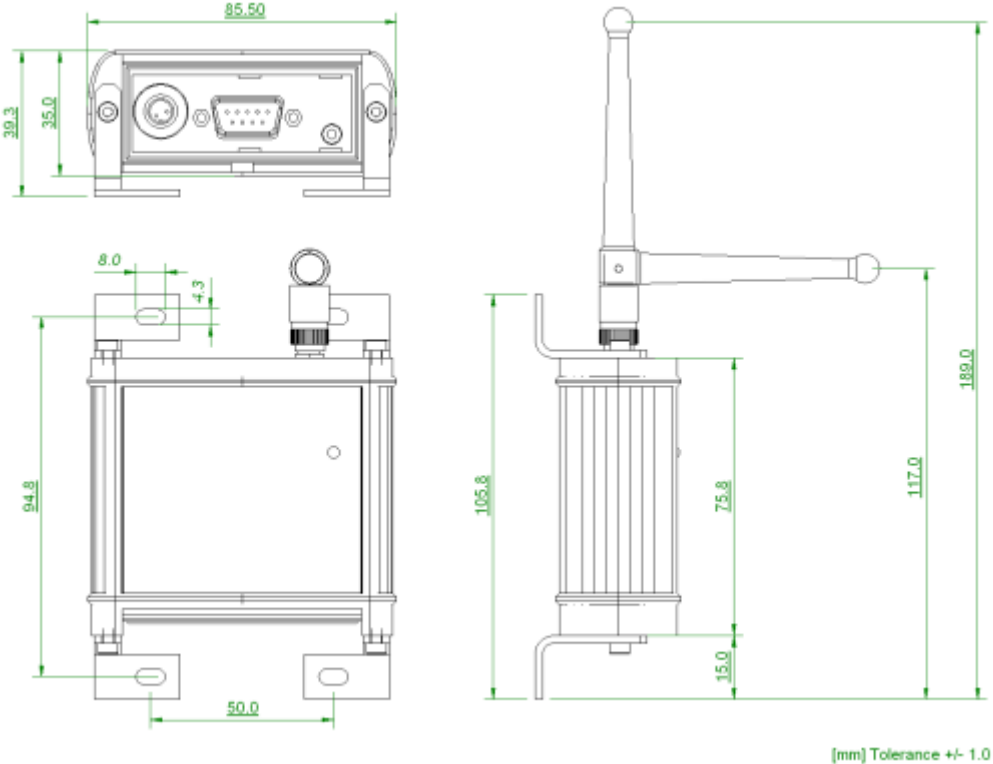

Figure 2. The gateway can be mounted using the mounting holes

The Wireless Bridge must only be used with the antenna provided with the product. Using another antenna will violate the regulatory type approval. The product cannot be mounted inside a shielded enclosure.

Power Supply

The product shall have a power supply of 8-30 VDC, 1 W on pin 1 (-) and 2 (+) on the power connector. Use a female power connector 712 series from Binder.

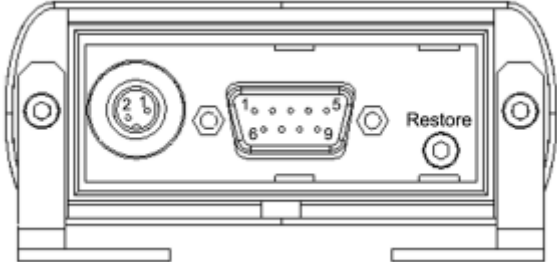

Figure 3. Power connector on the left side and the DSUB serial connector (male) in the middle

Current consumption

Current consumption measured at 30 V.

Mode		Value Unit	
Not connected	Connectable, discoverable	Average 14	mA
Not connected	Inquiry	Peak 26	mA
Connected	Idle	Average 18	mA
Connected	Transmitting @115.2kbit/s	Average 20	mA

RS232

This model supports RS232 with a male 9-pin DSUB:

- Pin 1: NC, not connected
- Pin 2: RD, input, receive data
- Pin 3: TD, output, transmit data
- Pin 4: DTR, output, data terminal ready
- Pin 5: GND, ground
- Pin 6: DSR, input, data set ready
- Pin 7: RTS, output, request to send
- Pin 8: CTS, input, clear to send
- Pin 9: NC, not connected

The model is designed to operate as a DTE (Data Terminal Equipment). When connecting the gateway to a DCE (Data Communication Equipment), e.g. a modem, a regular modem cable, straight cable, shall be used. When connecting the gateway to another DTE, e.g. a PC, a crossover serial cable must be used. The crossover cable must have TD and RD crossed (pins 2-3 and 3-2), RTS and CTS crossed (pins 7-8 and 8-7) and optionally DTR and DSR crossed (pins 4-6 and 6-4).

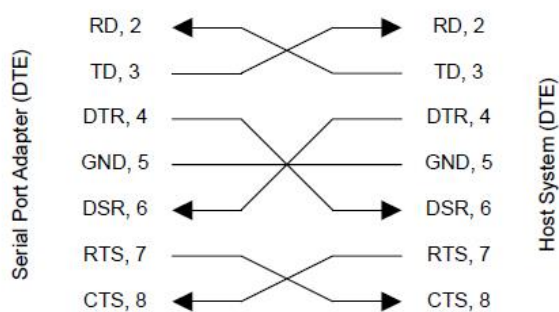

Figure 4. Crossover cable

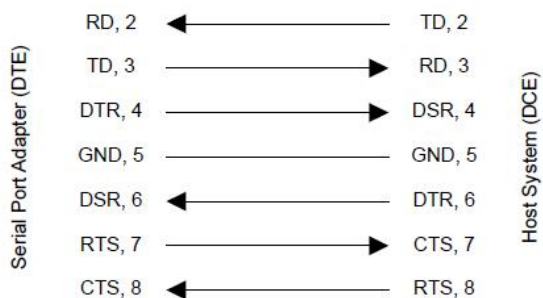

Figure 5. Straight cable

RS422

In this model, the same DSUB connector is used when using RS232, RS422 and RS485. However, in the case of RS422 and RS485, the pins have different meanings compared to RS232. For details please read the AT command specification document.

In the RS422 case, the following pinning is used:

- Pin 1: R-, input, receiver
- Pin 2: T-, output, transmitter
- Pin 3: NC, not connected
- Pin 4: NC, not connected
- Pin 5: NC, not connected
- Pin 6: R+, input, receiver
- Pin 7: NC, not connected
- Pin 8: T+, output, transmitter
- Pin 9: NC, not connected

For four-wire RS422 multidrop, the following connection setup shall be used:

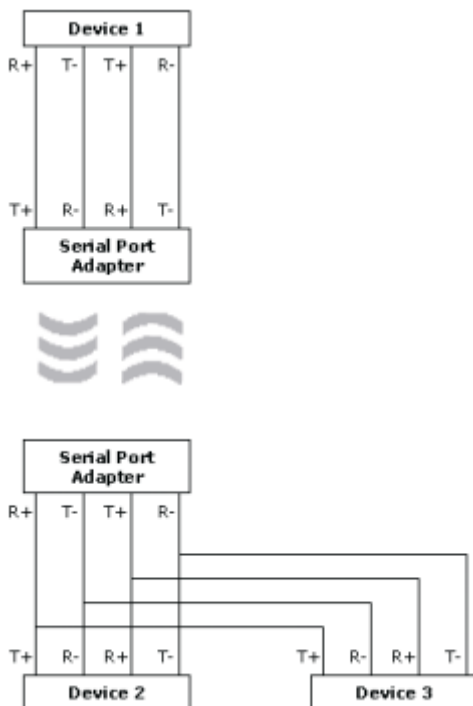

Figure 6. Four-wire RS422 connection setup.

Note: The definition of R+/R-,T+/T- may vary between manufacturers.

RS485

In the case of RS485, the same pinning as for RS422 is used, except that pins T- and R- must be connected externally and pins T+ and R+ must be connected externally to produce the signals T-/R- and T+/R+. For two-wire RS485 multidrop, the following connection setup shall be used:

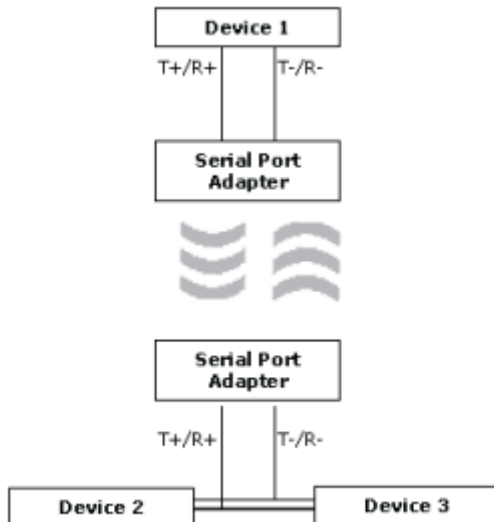

Figure 7. Two-wire RS485 connection setup.

Button and LED

If the *restore button* (see [Figure 3](#)) is pressed during power on, the default serial settings as well as the default escape sequence are restored. The status LED uses the following color indications.

- *Green*: The current mode is data mode and no connection attempt is in progress.
- *Orange*: The current mode is AT mode.
- *Purple*: A connection attempt is in progress.
- *Blue*: A connection is currently active.
- *Blue Blinking*: A connection is active and data is transmitted or received over air.
- *Red Blinking*: Buffer overflow, parity or framing error detected on the UART.

Regulatory Information

FCC Statement

This device complies with Part 15 of the FCC Rules. Operation is subject to the following two conditions: (1) this device may not cause harmful interference, and (2) this device must accept any interference received, including interference that may cause undesired operation.

NOTE: This equipment has been tested and found to comply with the limits for a Class B digital device, pursuant to Part 15 of the FCC Rules. These limits are designed to provide reasonable protection against harmful interference in a residential installation. This equipment generates, uses and can radiate radio frequency energy and, if not installed and used in accordance with the instructions, may cause harmful interference to radio communications. However, there is no guarantee that interference will not occur in a particular installation. If this equipment does cause harmful interference to radio or television reception, which can be determined by turning the equipment off and on, the user is encouraged to try to correct the interference by one or more of the following measures:

- Reorient or relocate the receiving antenna
- Increase the separation between the equipment and receiver
- Connect the equipment into an outlet on a circuit different from that to which the receiver is connected

Consult the dealer or an experienced radio/TV technician for help.

RF-Exposure Statement

This transmitter **MUST** have a separation distance of at least 20 cm between the antenna and the body of the user or nearby persons, excluding hands, wrists, feet, and ankles.

If the radio is installed in a laptop display, transmission **MUST** be prevented if the lid is closed to ensure that the minimum distance of 20 cm between the user and the transmitting antenna is maintained.

Any notification to the end user of installation or removal instructions about the integrated radio is **NOT** allowed.

Caution

Any changes or modifications **NOT** explicitly **APPROVED** by connectBlue AB could cause the device to cease to comply with FCC rules part 15, and thus void the user's authority to operate the equipment.

Declaration of Conformity



R&TTE Directive 1999/5/EC:

Effective use of frequency spectrum:
EN 300 328 V1.7.1 (2006-10)

EMC:

EN 301 489-1 V1.9.2 (2011-09)
EN 301 489-17 V2.2.1 (2012-09)
EN 61000-6-2 (2005)

Health and safety:

EN 62479:2010
EN 60950-1:2006 + A11:2009 + A1:2010 + A12:2011
IEC 60950-1:2005 + A1:2009

Medical Electrical Equipment

IEC 60601-1-2 (2007)

Bluetooth Qualification

The Anybus Wireless Bridge Serial - Bluetooth has been qualified according to the Bluetooth specification.

Device	Bluetooth specification	Referenced QDIDs
Anybus Wireless Bridge Serial - Bluetooth	4.0	B018179 combined with B020585

The following Bluetooth profiles are supported (covered functionality):

- Generic Access Profile (GAP)
- Service Discovery Application Profile (SDAP)
- Serial Port Profile (SPP)
- Dial-up Networking Profile (DUN GW, DUN DT)
- Personal Area Network Profile (PAN PANU, PAN NAP)
- Generic Attribute Profile (GATT)
- Device Information Service (DIS)
- connectBlue Low Energy Serial Port Service

Additional Information

Guidelines for Efficient and Safe Use

Read this information before using your gateway.

For any exceptions, due to national requirements or limitations, when using your gateway, please visit www.bluetooth.com.

Note: Changes or modifications to the product not expressly approved by HMS will void the user's authority to operate the equipment.

Product Care

- Do not expose your product to liquid or moisture.
- Do not expose your product to extreme hot or cold temperature (see Technical Specification for further information)
- Do not expose your product to lit candles, cigarettes, cigars, open flames, etc.
- Do not drop, throw or try to bend your product since rough treatment could damage your product.
- Do not attempt to disassemble your product. Doing so will void warranty. The product does not contain consumer serviceable or replaceable components. Service should only be performed by HMS.
- Do not paint your product as the paint could prevent normal use.
- If you will not be using your product for a while, store it in a place that is dry, free from damp, dust and extreme heat and cold.
- The clearance and creepage distances required by the end product must be withheld when the module is installed.
- The cooling of the end product shall not negatively be influenced by the installation of the module when the module is installed.

Radio Frequency Exposure

The gateway contains a small radio transmitter and receiver. During communication with other Bluetooth products the gateway receives and transmits radio frequency (RF) electromagnetic fields (microwaves) in the frequency range 2400 to 2500 MHz. The output power of the radio transmitter is very low.

When using the gateway, you will be exposed to some of the transmitted RF energy. This exposure is well below the prescribed limits in all national and international RF safety standards and regulations.

Electronic Equipment

Most modern electronic equipment, for example, in hospitals and cars, is shielded from RF energy. However, certain electronic equipment is not. Therefore:

Note: This equipment emits RF energy in the ISM (Industrial, Scientific, Medical) band. Please insure that all medical devices used in proximity to this device meet appropriate susceptibility specifications for this type of RF energy.

Potentially Explosive Atmospheres

Turn off your electronic device when in any area with potentially explosive atmosphere. It is rare, but your electronic device could generate sparks. Sparks in such areas could cause an explosion or fire resulting in bodily injury or even death. Areas with a potentially explosive atmosphere are often, but not always, clearly marked. They include fueling areas, such as petrol station, below deck on boats, fuel or chemical transfer or storage facilities, and areas where the air contains chemicals or particles, such as grain, dust, or metal powders.

Power Supply

The gateway must be supplied by a limited power source according to EN 60950-1.

- Connect your power supply only to designated power-sources as marked on the product.
- Make sure all cords and cable are positioned so that they will not be stepped on, tripped over or otherwise subject to damage or stress.
- To reduce risk of electric shock, unplug the unit from any power source before attempting to clean it.

Troubleshooting

This section lists some problems that you might encounter while using your Anybus Wireless Bridge Serial - Bluetooth.

1. I cannot connect. The data I send to the gateway does not arrive at the remote device.
 - Make sure that you have connected power to your gateway. The LED indicator should emit a green light when powered up, being ready to send and receive data.
 - Your gateway is not configured to use the same serial settings (e.g. baud rate) as your host system. Use the Toolbox to set the correct baud rate.
 - You have configured your gateway to act as a client but you have not selected a server device to connect to. Select a server device using the Toolbox.
 - Your gateway is too far away from the selected server device. Move the gateway closer to the server device.
 - You are not using the correct Bluetooth profile. Your gateway must be configured to use the same profile as the device you want to communicate with.
 - The remote device is not in connectable mode. If the server device is another gateway use the Toolbox to set the device in connectable mode. If the device is another Bluetooth device, consult the manual for that device to set it in connectable mode.
 - Make sure that the gateway is in transparent data mode (green light). Make sure that the gateway is not in configuration mode (orange light).

- If high security mode has been selected on one of the devices wanting to communicate, the two devices have to be paired with each other. Either disable security or perform pairing. Also, note that pairing is automatic during a connection setup if it is needed.
- 2. The Bluetooth link between my gateway and my selected remote peer disconnects.
 - Your gateway is configured to disconnect if no data is received or sent during a longer period of time. Use the Toolbox to disable the automatic disconnect or change the value of the timer.
 - Your gateway is too far away from the device it is communicating with. Move the two devices closer to each other.
- 3. There is no color on the LED indicator.
 - Make sure that power is connected to the gateway.
- 4. When I search for other devices using the Toolbox I cannot find the device I'm searching for.
 - The remote device is too far away. Move it closer to your gateway.
 - The remote device is not in discoverable mode. If the remote device is a gateway use the Toolbox to set it in discoverable mode. If the remote device is another device, consult the manual of that device to set it in discoverable mode.

Technical Specifications

Environmental

Storage temperature range: -40 / +85 °C
Operating temperature range: -30 / +85 °C
Humidity RH 5-90% non-condensing
Shock and vibration: IEC 61131-2

Radio Output Power

Radio mode	RF Output Power
Classic Bluetooth	12.0 dBm EIRP*
Bluetooth low energy	7.0 dBm EIRP*

* EIRP is including antenna gain.

0 dBm = 1 mW, 4dBm = 2,5 mW, 20 dBm = 100 mW.

Power Supply

Model	Power Supply
Anybus Wireless Bridge Serial - Bluetooth	8-30 VDC

Serial Interface

Model	Serial Interface
Anybus Wireless Bridge Serial - Bluetooth	RS232/RS422/RS485, male DSUB-9, 1200-460800 baud, CTS/RTS flow control or no flow control.

Housing

Model	Housing
Anybus Wireless Bridge Serial - Bluetooth	Aluminum housing, IP65.

Dimensions

Model	Dimensions (width x depth x height)
Anybus Wireless Bridge Serial - Bluetooth	75.8 x 85.5 x 35 mm (see Figure 2)